

भारतीय मानक
स्टेनलेस इस्पात के टक्करदार कब्जे — विशिष्टि
(दूसरा पुनरीक्षण)

Indian Standard
STAINLESS STEEL BUTT HINGES — SPECIFICATION
(*Second Revision*)

ICS 21.080; 91.060.50

© BIS 2013

BUREAU OF INDIAN STANDARDS
MANAK BHAVAN, 9 BAHADUR SHAH ZAFAR MARG
NEW DELHI 110002

FOREWORD

This Indian Standard (Second Revision) was adopted by the Bureau of Indian Standards, after the draft finalized by the Builder's Hardware Sectional Committee had been approved by the Civil Engineering Division Council.

Door hinges are made from different materials like mild steel, brass and aluminium. However, in the case of mild steel hinges in locations where atmospheric moisture levels are high, the hinges begin to rust. Stainless steel hinges are rust proof and are therefore especially useful in such areas having high atmospheric moisture content. Stainless steel is now abundantly available in our country and is being used for manufacture of hinges.

This standard was first published in 1989 and revised in 1997. In the first revision modifications with regard to the materials of flap and pin and requirements for light, heavy and unequal flap type stainless steel hinges were incorporated.

In this standard requirements for an additional type, medium weight (narrow) hinge have been incorporated. Further, unequal flap hinges have been categorized into two types, light weight unequal and heavy weight unequal flap hinges. In addition, provision for additional sizes of light weight (narrow) type hinges has also been incorporated.

The composition of the Committee responsible for the formulation of this standard is given in Annex B.

For the purpose of deciding whether a particular requirement of this standard is complied with, the final value, observed or calculated, expressing the result of a test or analysis, shall be rounded off in accordance with IS 2 : 1960 'Rules for rounding off numerical values (*revised*)'. The number of significant places retained in the rounded off value should be the same as that of the specified value in this standard,

Indian Standard

STAINLESS STEEL BUTT HINGES — SPECIFICATION

(*Second Revision*)

1 SCOPE

This standard covers types and requirements on materials, dimensions, manufacture and finish of stainless steel butt hinges.

2 REFERENCES

The following standards contain provisions which through reference in this text, constitute provisions of this standard. At the time of publication, the editions indicated were valid. All standards are subject to revision and parties to agreement based on this standard are encouraged to investigate the possibility of applying the most recent editions of the standards indicated below:

IS No.	Title
4905 : 1968	Methods for random sampling
6528 : 1995	Stainless steel wire — Specification (<i>first revision</i>)
6911 : 1992	Stainless steel plate, sheet and strip — Specification (<i>first revision</i>)

3 TYPES

Stainless steel butt hinges shall be of the following types:

- a) Light weight (narrow) hinges (*see* Table 1);
- b) Light weight unequal flap hinges (*see* Table 2);
- c) Medium weight hinges (*see* Table 3);
- d) Medium weight (narrow) hinges (*see* Table 4);
- e) Heavy weight unequal flap hinges (*see* Table 5); and

- f) Heavy weight hinges (*see* Table 6).

4 MATERIAL

4.1 The stainless steel for manufacture of hinges shall be as given in 4.1.1 and 4.1.2.

4.1.1 Flap

The stainless steel for flap shall conform to Grades X15 Cr16Ni2 or X07Cr18Ni9 of IS 6911.

4.1.2 Pin

The stainless steel for pin shall conform to grades X04Cr18Ni10 or X07Cr18Ni9 or X10Cr17Mn6Ni4N of IS 6528.

5 SIZE

The size of the hinge shall be denoted by the length (A) of the hinge.

6 DIMENSIONS AND TOLERANCES

6.1 Typical shapes of stainless steel butt hinges are shown in Fig. 1 and Fig. 2.

6.2 The dimensions and tolerances of various types of stainless steel hinges shall be as given in Tables 1 to 6.

7 MANUFACTURE

7.1 General

Hinges shall be well made and free from flaws and defects of any kind. All hinges shall be cut clean and square and shall be provided with stainless steel pin. The hole for the hinge pin shall be central and square.

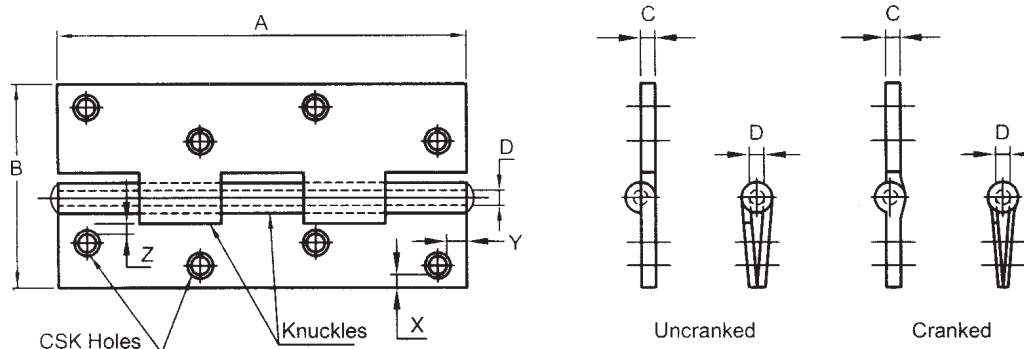

FIG. 1 TYPICAL SKETCH FOR LIGHT, MEDIUM AND HEAVY WEIGHT STAINLESS STEEL BUTT HINGES

to knuckles. All sharp edges and corners shall be removed.

7.2 Knuckles

The sides of knuckles shall be straight and at right angle to the flap. The movement of the hinges shall be free and easy, and working shall not have any play or shake. The number of knuckles in the hinges of different sizes shall be as specified in Tables 1 to 6.

7.3 Pins

The hinge pin shall be of diameters as specified in Tables 1 to 6 for different types and sizes of hinges. Pin shall fit inside the knuckle firmly and riveted head shall be well formed so as not to allow any play or shake. It shall allow easy movement of the hinge, but shall not cause looseness.

7.4 Screw Holes

All screw holes shall be clean and suitable for

countersunk head of wood screws of number as specified in Tables 1 to 6 for different types and sizes of hinges.

7.4.1 Number of Holes

The number of holes to be punched in different sizes of hinges shall be as specified in Tables 1 to 6. Hinges may also be supplied without holes in one flap or without holes in both flaps if required by purchaser.

7.4.2 Position of Holes

The centre line of the holes shall be parallel to the pin. In the heavy and medium weight hinges, when only two screw holes in each flap are provided they shall be in one line, but when more than two holes are provided in each flap they shall be distributed in zig-zag manner as shown in Fig. 1 and Fig. 2. In light weight and unequal flap hinges (both light weight and heavy weight), up to three holes are provided in one line, but when more than three holes are provided they shall be distributed in zig-zag manner as shown in Fig. 1. The distance of the screw holes from the end of the flap

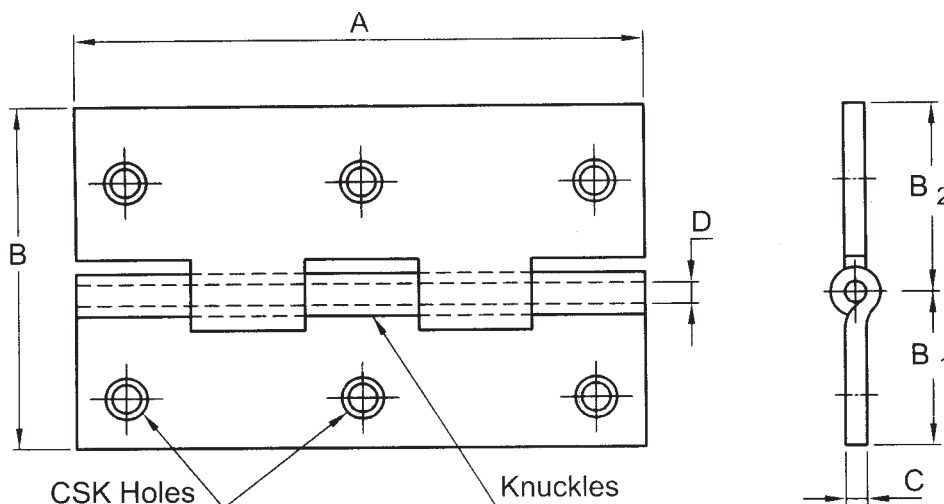

FIG. 2 TYPICAL SKETCH FOR UNEQUAL FLAP STAINLESS STEEL BUTT HINGES

Table 1 Dimensions and Tolerances of Light Weight (Narrow) Stainless Steel Butt Hinges
(Clauses 3, 6.2, 7.2, 7.3, 7.4 and 7.4.1)

Sl No.	Size of Hinge	Length	Breadth	Thickness of Flap	Dia of Hinge Pin	Number of Knuckles	Number of Screw Holes	Holes for Screw Number
		A	B	C	D			
(1)	(2)	mm	mm	mm	mm	(7)	(8)	(9)
i)	50	50 ± 0.5	31 ± 1	1.20 ± 0.15	2.6 ± 0.10	3	4	4
ii)	50	50 ± 0.5	37 ± 1	1.20 ± 0.15	2.6 ± 0.10	5	6	4
iii)	65	65 ± 0.5	40 ± 1	1.20 ± 0.15	2.8 ± 0.10	5	6	4
iv)	75	75 ± 0.5	31 ± 1	1.20 ± 0.15	2.8 ± 0.10	5	6	4
v)	75	75 ± 0.5	37 ± 1	1.20 ± 0.15	2.8 ± 0.10	5	6	4
vi)	75	75 ± 0.5	40 ± 1	1.20 ± 0.15	2.8 ± 0.10	5	6	4

NOTE — Dimension B is for uncranked hinge. For cranked hinge, this dimension will increase accordingly.

Table 2 Dimensions and Tolerances of Unequal Flap Light Weight Stainless Steel Butt Hinges
(Clauses 3, 6.2, 7.2, 7.3, 7.4 and 7.4.1)

Sl No.	Size of Hinge mm (2)	Length mm (3)	Breadth			Thickness of Flap C mm (7)	Dia of Hinge Pin D mm (8)	Number of Knuckles (9)	Number of Screw Holes (10)	Holes for Screw Number (11)
			B mm (4)	B ₁ mm (5)	B ₂ mm (6)					
i)	50 × 10 × 16	50 ± 0.5	31 ± 1	13.0 ± 0.5	18.0 ± 0.5	1.20 ± 0.15	2.6 ± 0.10	5	6	4
ii)	50 × 12 × 19	50 ± 0.5	37 ± 1	16.0 ± 0.5	21.0 ± 0.5	1.20 ± 0.15	2.6 ± 0.10	5	6	4
iii)	65 × 10 × 16	65 ± 0.5	31 ± 1	13.0 ± 0.5	18.0 ± 0.5	1.20 ± 0.15	2.6 ± 0.10	5	6	4
iv)	65 × 12 × 19	65 ± 0.5	37 ± 1	16.0 ± 0.5	21.0 ± 0.5	1.20 ± 0.15	3.4 ± 0.10	5	6	4
v)	75 × 10 × 16	75 ± 0.5	31 ± 1	13.0 ± 0.5	18.0 ± 0.5	1.20 ± 0.15	3.4 ± 0.10	5	6	4
vi)	75 × 12 × 19	75 ± 0.5	37 ± 1	16.0 ± 0.5	21.0 ± 0.5	1.20 ± 0.15	3.4 ± 0.10	5	6	4

Table 3 Dimensions and Tolerances of Medium Weight Stainless Steel Butt Hinges
(Clauses 3, 6.2, 7.2, 7.3, 7.4 and 7.4.1)

Sl No.	Size of Hinge mm (2)	Length mm (3)	Breadth B mm (4)	Thickness of Flap C mm (5)	Dia of Hinge Pin D mm (6)	Number of Knuckles (7)	Number of Screw Holes (8)	Holes for Screw Number (9)
ii)	65	65 ± 0.5	42 ± 1	1.60 ± 0.15	3.55 ± 0.10	5	6	5
iii)	75	75 ± 0.5	47 ± 1	1.80 ± 0.15	4.00 ± 0.10	5	6	7
iv)	100	100 ± 0.5	58 ± 1	1.90 ± 0.15	5.60 ± 0.10	5	8	8
v)	125	125 ± 0.5	64 ± 1	1.90 ± 0.15	5.60 ± 0.10	5	8	9
vi)	150	150 ± 0.5	70 ± 1	1.90 ± 0.15	5.60 ± 0.10	5	8	9

NOTE — Dimension *B* is for uncranked hinge. For cranked hinge, this dimension will increase accordingly.

Table 4 Dimensions and Tolerances of Medium Weight (Narrow) Stainless Steel Butt Hinges
(Clauses 3, 6.2, 7.2, 7.3, 7.4 and 7.4.1)

Sl No.	Size of Hinge mm (2)	Length mm (3)	Breadth B mm (4)	Thickness of Flap C mm (5)	Dia of Hinge Pin D mm (6)	Number of Knuckles (7)	Number of Screw Holes (8)	Holes for Screw Number (9)
ii)	100	100 ± 0.5	47 ± 1	1.50 ± 0.15	3.40 ± 0.10	5	6	6

NOTE — Dimension *B* is for uncranked hinge. For cranked hinge, this dimension will increase accordingly.

Table 5 Dimensions and Tolerances of Unequal Flap Heavy Weight Stainless Steel Butt Hinges
(Clauses 3, 6.2, 7.2, 7.3, 7.4 and 7.4.1)

Sl No.	Size of Hinge mm (2)	Length mm (3)	Breadth			Thickness of Flap C mm (7)	Dia of Hinge Pin D mm (8)	Number of Knuckles (9)	Number of Screw Holes (10)	Holes for Screw Number (11)
			B mm (4)	B ₁ mm (5)	B ₂ mm (6)					
i)	75 × 10 × 16	75 ± 0.5	33 ± 1	14 ± 0.5	19 ± 0.5	1.5 ± 0.15	3.4 ± 0.10	5	6	6
ii)	75 × 13 × 19	75 ± 0.5	37 ± 1	15.5 ± 0.5	21.5 ± 0.5	1.5 ± 0.15	3.4 ± 0.10	5	6	6
iii)	100 × 13 × 19	100 ± 0.5	40 ± 1	17 ± 0.5	23 ± 0.5	1.5 ± 0.15	3.4 ± 0.10	5	6	6

Table 6 Dimensions and Tolerances of Heavy Weight Stainless Steel Butt Hinges
(Clauses 3, 6.2, 7.2, 7.3, 7.4 and 7.4.1)

Sl No.	Size of Hinge	Length	Breadth	Thickness of Flap	Dia of Hinge Pin	Number of Knuckles	Number of Screw Holes	Holes for Screw Number
		A	B	C	D			
(1)	mm	mm	mm	mm	mm	(7)	(8)	(9)
i)	75	75 ± 0.5	47 ± 1	2.50 ± 0.15	4.0 ± 0.10	5	6	7
ii)	100	100 ± 0.5	59 ± 1	2.50 ± 0.15	5.6 ± 0.10	5	8	8
iii)	125	125 ± 0.5	65 ± 1	2.50 ± 0.15	5.6 ± 0.10	5	8	9
iv)	150	150 ± 0.5	75 ± 1	2.50 ± 0.15	5.6 ± 0.10	5	8	10

NOTE — Dimension *B* is for uncranked hinge. For cranked hinge, this dimension will increase accordingly.

either parallel to the pin or across it, shall be as follows:

- a) *X* or *Y* (Min)
 - 1) *Light Weight (Narrow) and Medium Weight (Narrow)* (see Fig. 1):
For hinges of 50 mm, 65 mm, : 3.5 mm
75 mm or 100 mm
 - 2) *Medium and Heavy Weight* (see Fig. 1):
 - i) For hinges up to 65 mm size: 3.5 mm
 - ii) For hinges of 75 mm and : 5 mm
100 mm size
 - iii) For hinges of 125 mm size : 7 mm
and above
 - 3) *Unequal Flap* (see Fig. 2):
For hinges of 50 mm, 65 mm, : 3 mm
75 mm or 100 mm
- b) *Z* (Min)
 - 1) *Light Weight (Narrow) and Medium Weight (Narrow)* (see Fig. 1):
For hinges of 50 mm, 65 mm, : 3 mm
75 mm or 100 mm
 - 2) *Medium and Heavy Weight* (see Fig. 1):
 - i) For hinges up to 65 mm : 4 mm
 - ii) For hinges of 75 mm or : 4 mm
100 mm
 - iii) For hinges of 125 mm and : 4 mm
above
 - 3) *Unequal Flap* (see Fig. 2):
For hinges of 50 mm, 65 mm, : 2 mm
75 mm or 100 mm

where

- X* = distance of the hole from the end of flap measured parallel to the pin;
Y = distance of end hole from the end flap measured at right angle to the pin; and
Z = distance of end hole nearest to knuckle edge,

where holes are provided in zig-zag manner, from the edge of knuckle slot.

8 FINISH

Unless otherwise specified, hinges shall be naturally finished bright with smooth surface without chemical coating.

9 SAMPLING AND CRITERION FOR CONFORMITY

The method of sampling hinges and the criterion for conformity shall be as given in Annex A.

10 MARKING

Each hinge shall be legibly and indelibly marked with the manufacturer's name or trade-mark and type on the body, either inside or outside as found convenient to the manufacturer.

10.1 BIS Certification Marking

Each hinge may also be marked with the Standard Mark.

10.1.1 The use of the Standard Mark is governed by the provisions of the *Bureau of Indian Standards Act, 1986* and Rules and Regulations made thereunder. The details of conditions under which the licence for the use of the Standard Mark may be granted to manufacturers or producers may be obtained from the Bureau of Indian Standards.

11 PACKING

Hinges shall be packed in cardboard boxes or any other approved packing in the following quantities or multiples of 5:

- a) 50, 65, 75 mm size — 20 pieces in each package; and
- b) 100, 125, 150 mm size — 10 pieces in each package.

ANNEX A
(Clause 9)

SAMPLING AND CRITERION FOR CONFORMITY

A-1 LOT

In any consignment, all the butt hinges of the same type and size and manufactured from similar materials under identical conditions of manufacture shall be grouped together to constitute a lot.

A-2 SAMPLE SIZE

A-2.1 The number of butt hinges to be selected from a lot shall depend on the size of lot and shall be in accordance with col 2 and col 3 of Table 7.

A-2.2 Butt hinges for testing shall be selected at random from at least 10 percent of the packages subject to a minimum of three equal number of hinges being selected from each such package. In order to ensure the randomness of selection, procedure given in IS 4905 may be followed.

A-3 TESTS

All butt hinges selected as in **A-2** shall be checked for dimension and tolerance (*see 6*), manufacture (*see 7*), and finish (*see 8*). Any hinge which fails to satisfy the requirements of any one or more of the characteristics shall be considered as defective hinge.

A-4 CRITERION FOR CONFORMITY

A lot shall be considered as conforming to the requirements of this standard if the number of defective hinges among those tested does not exceed the corresponding acceptance number given in col 4 of Table 7. If the number of defectives is greater than or equal to rejection number given in col 5 of Table 7, the lot shall be deemed as not meeting the requirements of this standard.

Table 7 Scale of Sampling and Criterion for Conformity
(Clauses A-2.1 and A-4)

Sl No. (1)	Lot Size (2)	Sample Size (3)	Acceptance Number (4)	Rejection Number (5)
i)	Up to 50	13	1	2
ii)	51 to 90	20	1	2
iii)	91 to 150	32	2	3
iv)	151 to 280	50	3	4
v)	281 to 500	80	5	6
vi)	501 to 1 200	125	7	8
vii)	1 201 and above	200	10	11

ANNEX B

(Foreword)

COMMITTEE COMPOSITION

Builder's Hardware Sectional Committee, CED 15

<i>Organization</i>	<i>Representative(s)</i>
In personal capacity (1421, Sector A, Pocket B & C, Vasant Kunj, New Delhi 110070)	SHRI B. MAJUMDAR (Chairman)
Allied Anodisers, Kolkata	SHRI SUSHIL TAWAR
Apex Association of DDA Colonies (Regd), Delhi	SHRI R. P. AGRAWAL SHRI R. R. SHARMA (<i>Alternate</i>)
Argent Industries, New Delhi	SHRI ANIL CHADHA SHRIMATI VANITA CHADHA (<i>Alternate</i>)
Builders Association of India, New Delhi	SHRI RAJ PAL AURORA SHRI H. S. PASRICHA (<i>Alternate</i>)
Building Materials & Technology Promotion Council, New Delhi	SHRI B. ANIL KUMAR SHRI V. K. SETHI (<i>Alternate</i>)
Central Building Research Institute, Roorkee	SHRI D. K. GAUTAM SHRI S. K. NEGI (<i>Alternate</i>)
Central Public Works Department, New Delhi	SHRI SURESH KUMAR SHRI MAYANK K. TILAK (<i>Alternate</i>)
Construction Industries Development Council, New Delhi	SHRI P. R. SWARUP SHRI RAJEEV JAIN (<i>Alternate</i>)
D. P. Garg & Company Pvt Ltd, Noida	SHRI S. M. GARG SHRI R. C. MALHOTRA (<i>Alternate</i>)
Delhi Development Authority, New Delhi	CHIEF ENGINEER (NZ) SUPERINTENDING ENGINEER (CIVIL CIRCLE-13) (<i>Alternate</i>)
Engineer-in-Chief's Branch, New Delhi	SHRI P. MAKHIJANI SHRI A. K. GUPTA (<i>Alternate</i>)
Garnish Traders, New Delhi	SHRI H. S. SETHI SHRIMATI HARMEET SETHI (<i>Alternate</i>)
Godrej & Boyce Manufacturing Co Limited, Mumbai	SHRI T. S. MURALI SHRI K. N. MODI (<i>Alternate</i>)
Hindalco Industries Limited, Distt Sonbhadra	SHRI V. K. AGGARWAL SHRI S. S. SINGHVI (<i>Alternate</i>)
Jindal Aluminium Limited, Bangalore	REPRESENTATIVE
Indian Institute of Architects, New Delhi	DR ABHIJIT RAY
M.C. Mowjee & Co Pvt Limited, Kolkata	SHRI SAJID MOWJEE
MECH (India) Industries, Delhi	SHRI SUDHIR BATRA SHRI RAJESH VASUDEVA (<i>Alternate</i>)
Ministry of Micro, Small and Medium Enterprises, New Delhi	SHRI J. K. ARYA SHRI K. K. FUNDA (<i>Alternate</i>)
Ministry of Railways, New Delhi	REPRESENTATIVE
National Real Estate Development Council, New Delhi	BRIG (RETD) R. R. SINGH SHRI SUMIT JHA (<i>Alternate</i>)
National Test House, Kolkata	DR P. KANJILAL SHRI ANIL CHOPRA (<i>Alternate</i>)
National Thermal Power Corporation Limited, New Delhi	REPRESENTATIVE
BIS Directorate General	SHRI A. K. SAINI, Scientist 'F' and Head (CED) [Representing Director General (<i>Ex-officio</i>)]

Member Secretary
SHRI J. ROY CHOWDHURY
Scientist 'E' (CED), BIS

Bureau of Indian Standards

BIS is a statutory institution established under the *Bureau of Indian Standards Act, 1986* to promote harmonious development of the activities of standardization, marking and quality certification of goods and attending to connected matters in the country.

Copyright

BIS has the copyright of all its publications. No part of these publications may be reproduced in any form without the prior permission in writing of BIS. This does not preclude the free use, in the course of implementing the standard, of necessary details, such as symbols and sizes, type or grade designations. Enquiries relating to copyright be addressed to the Director (Publications), BIS.

Review of Indian Standards

Amendments are issued to standards as the need arises on the basis of comments. Standards are also reviewed periodically; a standard along with amendments is reaffirmed when such review indicates that no changes are needed; if the review indicates that changes are needed, it is taken up for revision. Users of Indian Standards should ascertain that they are in possession of the latest amendments or edition by referring to the latest issue of 'BIS Catalogue' and 'Standards : Monthly Additions'.

This Indian Standard has been developed from Doc No.: CED 15 (7638).

Amendments Issued Since Publication

Amend No.	Date of Issue	Text Affected

BUREAU OF INDIAN STANDARDS

Headquarters:

Manak Bhavan, 9 Bahadur Shah Zafar Marg, New Delhi 110002
Telephones : 2323 0131, 2323 3375, 2323 9402 Website: www.bis.org.in

Regional Offices:

	Telephones
Central : Manak Bhavan, 9 Bahadur Shah Zafar Marg NEW DELHI 110002	{ 2323 7617 2323 3841
Eastern : 1/14 C.I.T. Scheme VII M, V. I. P. Road, Kankurgachi KOLKATA 700054	{ 2337 8499, 2337 8561 2337 8626, 2337 9120
Northern : SCO 335-336, Sector 34-A, CHANDIGARH 160022	{ 60 3843 60 9285
Southern : C.I.T. Campus, IV Cross Road, CHENNAI 600113	{ 2254 1216, 2254 1442 2254 2519, 2254 2315
Western : Manakalaya, E9 MIDC, Marol, Andheri (East) MUMBAI 400093	{ 2832 9295, 2832 7858 2832 7891, 2832 7892

Branches: AHMEDABAD. BANGALORE. BHOPAL. BHUBANESHWAR. COIMBATORE. DEHRADUN. FARIDABAD. GHAZIABAD. GUWAHATI. HYDERABAD. JAIPUR. KANPUR. LUCKNOW. NAGPUR. PARWANOO. PATNA. PUNE. RAJKOT. THIRUVANANTHAPURAM. VISAKHAPATNAM.